

Simplify
your
Ride



One pass is all
you need
to ride all day.

To help you to better understand HRT's bus schedule, we have provided the following route planning example. Please refer to the sample timetable.

The bus stops here at listed times. Look for the matching symbol below the map.

The bus stops at each of the times listed below the symbol.

The timetable shows WHEN the bus stops. Times are approximate and depend upon traffic and weather conditions. Arrive at the bus stop 2-3 minutes early to avoid missing the bus.

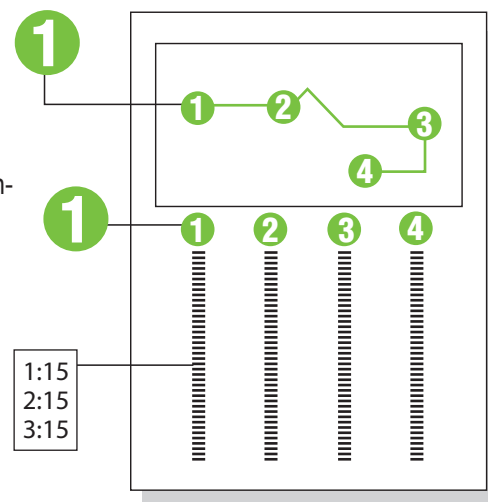

757-222-6100
gohrt.com

NORTHSIDE

Hampton • Newport News

When buses depart Northside Garage at Victoria Blvd. and Algonquin Rd., customers are permitted to ride from this location to the starting place of that vehicle. When buses pull into Northside Garage at Victoria Blvd. and Algonquin Rd., customers are permitted to ride service from the last stop to Victoria Blvd. and Algonquin Rd. This service will operate express and no other stops will be made. For scheduled times please contact Customer Service at 222-6100.

SOUTHSIDE

When buses depart Southside Garage at Ford Dr. and Indian River Rd., customers are permitted to ride from this location to the starting place of that vehicle. When buses pull into Southside Garage at Ford Dr. and Lindsay Ave., customers are permitted to ride service from the last stop to Ford Dr. and Indian River Rd. This service will operate express and no other stops will be made. For scheduled times please contact Customer Service at 222-6100.

Virginia Beach

When buses depart Virginia Beach Garage at Parks Ave. and 15th St., customers are permitted to ride from this location to the starting place of that vehicle. When buses pull into Virginia Beach Garage at Parks Ave. and 15th St., customers are permitted to ride service from last stop to Parks Ave. and 15th St. This service will operate express and no other stops will be made. For scheduled times please contact Customer Service at 222-6100.

Military or Contractors ID are required for all passengers before entering Military Installations. A security check will take place at the Main Gate. Failure to comply will result in being denied access to the base.

HRT will operate reduced service on most holidays. For holiday times please call HRT Customer Service at 222-6100 or visit our website at gohrt.com.

Schedule subject to change.

FOR MORE INFORMATION

Customer Service 757-222-6100
Monday-Friday: 7:30 a.m. to 9 p.m.
Saturday: 7 a.m. to 9 p.m.
Sunday: 9 a.m. to 5 p.m. Holidays: 9 a.m. to 4 p.m.

TICKET SALES

Silverleaf Commuter Station, Virginia Beach

Monday-Friday: 5 a.m. to 5 p.m.

Newport News Transportation Center

Monday-Friday: 6 a.m. to 7 p.m.

Saturday: 7 a.m. to 5 p.m.

Sunday: 9 a.m. to 1 p.m.

Hampton Transportation Center

Monday-Friday: 6 a.m. to 7 p.m.

Saturday: 7 a.m. to 5 p.m.

Sunday: 9 a.m. to 1 p.m.

Lost & Found 757-222-6100

Monday-Friday: 8 a.m. to 5 p.m.

TRAFFIX Commuter Programs 1-800-700-RIDE

Monday-Friday: 8 a.m. to 5 p.m.

TDD line or after hours 757-722-8427

Web site gohrt.com

Compliments & Suggestions

HRT welcomes your input. If you have any request, suggestions, recommendations or information that will help improve our service, please call 757-222-6036, Monday through Friday between 8 a.m. and 5 p.m. or anytime on line at gohrt.com.

HRT BUS FARE

Adult	\$1.50
Senior/Person with disabilities	\$0.75*
Youth (up to age 18)	\$1.00*
Child under 38"	FREE
Go 1 Day Pass	\$3.50
Go 1 Day Pass Senior, Disabilities, Youth	\$1.75
Go 1 Day (Bundle of 5)	\$16.50
Go 1 Day Senior, Disabilities, Youth (Bundle of 5)	\$8.75
Go 7 Day Pass	\$17.00
Go 30 Day Pass	\$50.00
Go 30 Day Senior, Disabilities, Youth	\$35.00

MAX FARE INFORMATION

Adult	\$3.00
Youth (17 and under)	\$3.00
Seniors and Persons with Disabilities	\$1.50
Child (under 38" tall)	FREE
1-Day MAX Pass	\$5.50
(unlimited rides on Express, Regular, Ferry, VB Wave and Shuttle services)	
5-Pack of 1-Day MAX Passes	\$24.75
(unlimited rides on Express, Regular, Ferry, VB Wave and Shuttle services)	
30-Day MAX Pass	\$95.00
(unlimited rides on Express, Regular, Ferry, VB Wave and Shuttle services)	
1-Day Passes available at the farebox.	

- * Youth, 17 and under, are required to show the driver an ID which includes age and photograph.
- ** Senior citizens, age 60 and over, must show the driver a DMV, Medicare ID or any other proof of age which includes a photograph. Persons with Disabilities must show HRT Half-fare, ADA Paratransit ID.

Wheelchair Lift Equipped Bike Rack Equipped

HRT ROUTE 47
Hampton Roads Transit

Serving:

Downtown Portsmouth /
Churchland



gohrt.com

Effective January 31, 2010

ROUTE 47 Downtown Portsmouth / Churchland

Effective January 31, 2010

LEGEND

- Weekday
- Streets
- Time Point
- Connecting Bus Routes

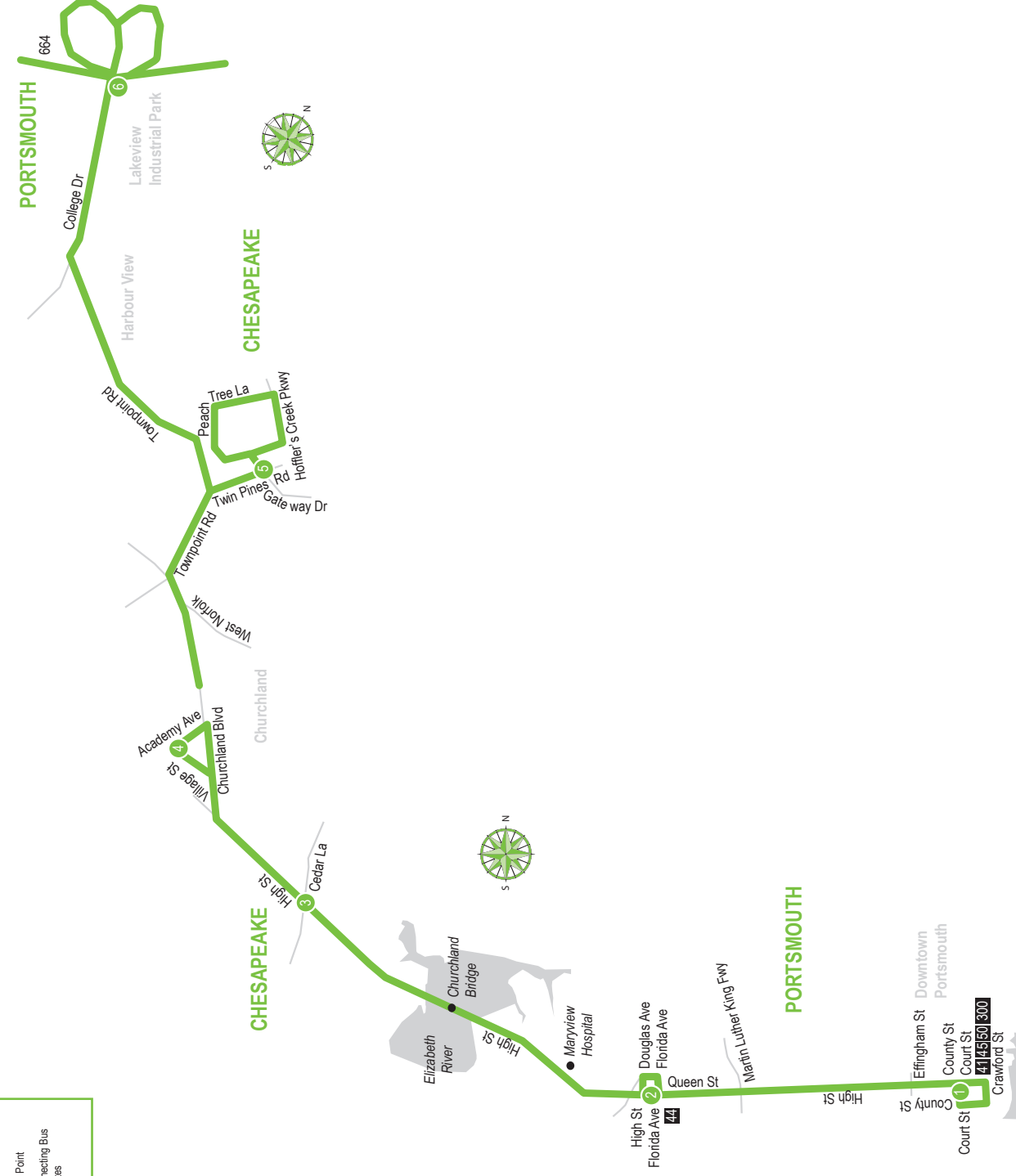

WEEKDAY: From Downtown Portsmouth to Village St & Academy Ave to Lakeview Industrial Park

- 1
- 2
- 3
- 4
- 5
- 6

	1	2	3	4	5	6
A.M.	6:03	6:18	6:28	6:33	6:37	6:50
	6:33	6:48	6:58	7:03	7:37	7:50
	7:03	7:18	7:28	7:33	8:07	8:20
	7:33	7:48	7:58	8:03	8:37	8:50
	8:03	8:18	8:28	8:33	9:07	9:20
	8:33	8:48	8:58	9:03	9:37	9:50
	9:03	9:18	9:26	9:31	10:05	10:18
	9:33	9:48	9:56	10:01	10:35	10:48
	10:03	10:18	10:26	10:31	11:05	11:18
	10:33	10:48	10:56	11:01	11:35	11:48
	11:03	11:18	11:26	11:31	12:05	12:18
	11:33	11:48	11:56	12:01	12:35	12:48
P.M.	12:03	12:18	12:26	12:31	12:35	12:48
	12:33	12:48	12:56	1:01	1:35	1:48
	1:03	1:18	1:26	1:31	2:05	2:18
	1:33	1:48	1:56	2:01	2:35	2:48
	2:03	2:18	2:26	2:31	3:05	3:18
	2:33	2:48	2:56	3:01	3:35	3:48
	3:03	3:18	3:26	3:33	4:05	4:18
	3:33	3:48	3:56	4:03	4:35	4:48
	4:03	4:18	4:26	4:33	5:05	5:18
	4:33	4:48	4:56	5:03	5:35	5:48
	5:03	5:18	5:26	5:33	6:05	6:18
	5:33	5:48	5:56	6:03	6:35	6:48
	6:03	6:18	6:26	6:31	7:05	7:18
	6:33	6:48	6:56	7:01	—	—

WEEKDAY: From Lakeview Industrial Park to Village St & Academy Ave to Downtown Portsmouth

- 6
- 5
- 4
- 3
- 2
- 1

	6	5	4	3	2	1
A.M.	5:43	5:54	6:01	6:07	6:18	6:30
	6:43	6:54	7:01	7:07	7:18	7:30
	7:43	7:54	8:01	8:07	8:18	8:30
	8:44	8:55	9:02	9:07	9:18	9:30
	9:48	9:58	10:04	10:09	10:18	10:30
	10:48	10:58	11:04	11:09	11:18	11:30
	11:48	11:58	12:04	12:09	12:18	12:30
P.M.	12:48	12:58	1:04	1:09	1:18	1:30
	1:48	1:58	2:04	2:09	2:18	2:30
	2:43	2:54	3:01	3:07	3:18	3:30
	3:43	3:54	4:01	4:07	4:18	4:30
	4:43	4:54	5:01	5:07	5:18	5:30
	5:44	5:55	6:02	6:07	6:18	6:30
	—	—	7:02	7:07	7:18	7:30

SATURDAY: From Downtown Portsmouth to Village St & Academy Ave

- 1
- 2
- 3
- 4

	1	2	3	4
A.M.	6:03	6:15	6:26	6:32
	6:33	6:45	6:56	7:02
	7:03	7:15	7:26	7:32
	7:33	7:45	7:56	8:02
	8:03	8:15	8:26	8:32
	8:33	8:45	8:56	9:02
	9:03	9:15	9:26	9:32
	9:33	9:45	9:56	10:02
	10:03	10:15	10:26	10:32
	10:33	10:45	10:56	11:02
	11:03	11:15	11:26	11:32
	11:33	11:45	11:56	12:02
P.M.	12:03	12:15	12:26	12:32
	12:33	12:45	12:56	1:02
	1:03	1:15	1:26	1:32
	1:33	1:45	1:56	2:02
	2:03	2:15	2:26	2:32
	2:33	2:45	2:56	3:02
	3:03	3:15	3:26	3:32
	3:33	3:45	3:56	4:02
	4:03	4:15	4:26	4:32
	4:33	4:45	4:56	5:02
	5:03	5:15	5:26	5:32
	5:33	5:45	5:56	6:02
	6:03	6:15	6:26	6:32
	6:33	6:45	6:56	7:02

SATURDAY: From Village St & Academy Ave to Downtown Portsmouth

- 4
- 3
- 2
- 1

	4	3	2	1
A.M.	6:32	6:37	6:45	7:00
	7:02	7:07	7:15	7:30
	7:32	7:37	7:45	8:00
	8:02	8:07	8:15	8:30
	8:32	8:37	8:45	9:00
	9:02	9:07	9:15	9:30
	9:32	9:37	9:45	10:00
	10:02	10:07	10:15	10:30
	10:32	10:37	10:45	11:00
	11:02	11:07	11:15	11:30
	11:32	11:37	11:45	12:00
	12:02	12:07	12:15	12:30
P.M.	12:32	12:37	12:45	1:00
	1:02	1:07	1:15	1:30
	1:32	1:37	1:45	2:00
	2:02	2:07	2:15	2:30
	2:32	2:37	2:45	3:00
	3:02	3:07	3:15	3:30
	3:32	3:37	3:45	4:00
	4:02	4:07	4:15	4:30
	4:32	4:37	4:45	5:00
	5:02	5:07	5:15	5:30
	5:32	5:37	5:45	6:00
	6:02	6:07	6:15	6:30
	6:32	6:37	6:45	7:00
	7:02	7:07	7:15	7:30